

## 31113 HIBO LED N 150W-NW

High-bay LED light fitting

8595665311131

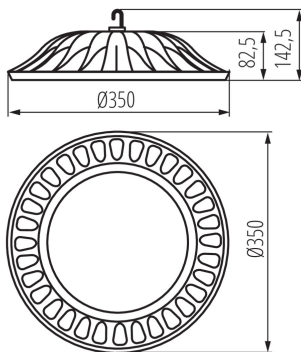

HIBO LED is a "High Bay" luminaire using a LED module with SMD diodes. The luminaire has a high rating of tightness IP65, thanks to which it can be mounted in places of high dustiness and exposed to water. It is an industrial luminaire suitable for lighting of storehouses, production halls and large commercial spaces.

### TYPE OF LIGHT SOURCE:

**Lighting technology used:** LED  
**Non-directional or directional light source:** DLS  
**Mains or non-mains light source:** MLS  
**Connected light source (CLS):** no  
**Colour-tuneable light source:** no  
**High luminance light source:** no  
**Anti-glare shield:** no  
**Dimmable:** no

### PRODUCT PARAMETERS:

**Colour:** black  
**Place of assembly:** ceiling mounted  
**Place of application:** Indoors and outdoors  
**Minimum distance from the illuminated object:** 1m  
**Compatible with a dimmer:** no  
**Replaceable light source:** no  
**Fixture lighting direction:** down  
**Diameter [mm]:** 350  
**Wire length [m]:** 0.45  
**Mercury content:** no  
**Integrated LED light source:** yes  
**Rated voltage [V]:** 220-240 AC  
**Rated frequency [Hz]:** 50/60  
**Maximum power [W]:** 150  
**Class of protection against electric shock:** I  
**Diode type:** LED SMD  
**Luminous flux [lm]:** 13500  
**Colour temperature:** white  
**Service life [h]:** 25000  
**Number of on/off cycles:**  $\geq 20000$   
**Lighting angle [°]:** 120  
**Ambient temperature range to which the product can be exposed:** -20÷40  
**Enclosure material:** aluminum alloy  
**Protective glass material:** glass  
**Connection type:** Free cable ends  
**Wire type:** H05RN-F

## 31113 HIBO LED N 150W-NW

High-bay LED light fitting

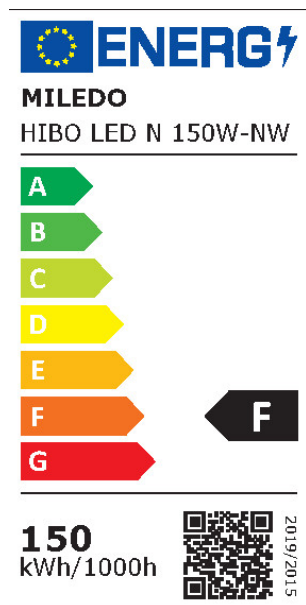

Wire diameter [mm<sup>2</sup>]: 1  
Lamp-heating time [s]: ≤1  
Lamp-ignition time [s]: ≤0,5  
IP class: 65

### GENERAL PRODUCT PARAMETERS:

Energy consumption in on-mode (kWh/1000h): 150  
Energy efficiency class: F  
Useful luminous flux  $\Phi_{use}$  [lm]: in wide cone (120°)  
Correlated colour temperature [K]: 4000  
On-mode power  $P_{on}$  [W]: 150  
Height [mm]: 143  
Colour rendering index: 80  
Chromaticity coordinates (x): 0.38  
Chromaticity coordinates (y): 0.38

### PARAMETERS FOR DIRECTIONAL LIGHT SOURCES:

Beam angle [°]: 120

### PARAMETERS FOR LED AND OLED LIGHT SOURCES:

Survival factor: ≥0.9  
The lumen maintenance factor: 0.96

### PARAMETERS FOR LED AND OLED MAINS LIGHT SOURCES:

Displacement factor ( $\cos \phi_1$ ): 0.9  
Colour consistency in McAdam ellipses: ≤6  
LED light source replaces a fluorescent light source without integrated ballast of a particular wattage: Not applicable  
Flicker metric (Pst LM): ≤1,0  
Stroboscopic effect metric (SVM): ≤0,4

### LOGISTIC DATA:

Unit of measurement: unit  
Packaging method: 1  
Number of units in the secondary packaging: 1  
Number of units in the packaging: 1  
Net unit weight [g]: 3050  
Grammage [g]: 3380  
Length of a unit pack [cm]: 36  
Width of a unit pack [cm]: 37  
Height of a unit pack [cm]: 11.5  
Weight of a cardboard box [kg]: 3.38  
Width of a cardboard box [cm]: 37  
Height of a cardboard box [cm]: 11.5  
Length of a cardboard box [cm]: 36  
Volume of a cardboard box [m<sup>3</sup>]: 0.015318

## 31113 HIBO LED N 150W-NW

High-bay LED light fitting

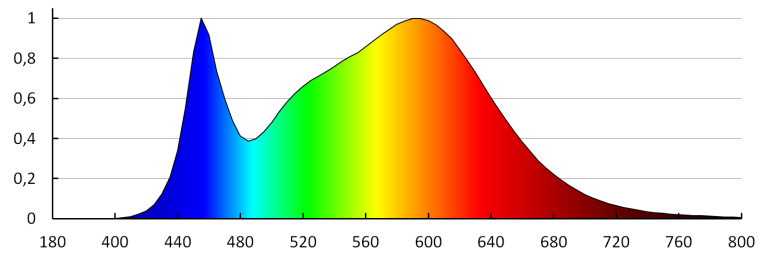

MILED0 (kat 31113) HIBO LED N 150W-NW / LDC (Polar)

Luminaire: MILED0 (kat 31113) HIBO LED N 150W-NW  
Lamps: 1 x HIBO LED 150W-NW

